



WTB balances are designed for fast and precise determination of mass in laboratory conditions.

They can be used in locations where no power (230V) is accessible as they are equipped with internal rechargeable battery.

Balances are equipped with stainless steel weighing pan, RS 232 output and backlit LCD display.



Counting pieces



Percentage



Weighing animals



Summing function



+/- control



Peak hold of maximal indication

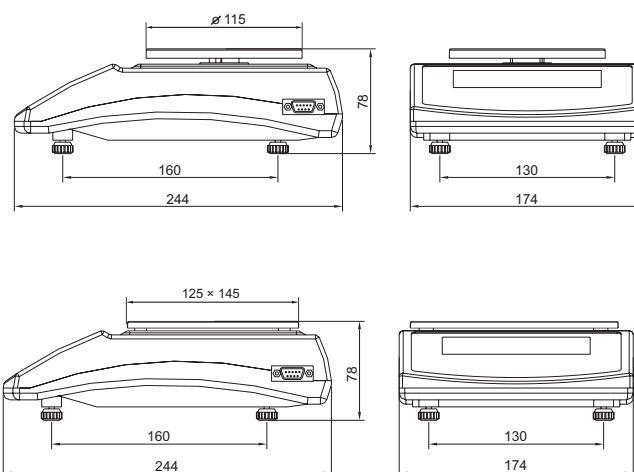

Technical data:

	WTB 200	WTB 2000
Maximal capacity	200 g	2000 g
Readability	0,001 g	0,01 g
Tare range	-200 g	-2000 g
Repeatability	0,003 g	0,03 g
Linearity	±0,003 g	±0,03 g
Working temperature	+15° - +30° C	
Power supply	230V / 11V AC or 120V / 11V AC and 6×AA NiMH accumulator	
IP rating	IP 43	
Pan size	∅ 115 mm	125 × 145 mm
Display	LCD (backlit)	

Additional equipment:

RACK FOR HEAD	EXTERNAL RECHARGEABLE BATTERY PACK
LCD ADDITIONAL DISPLAY	COMPUTER SOFTWARE: PW-WIN, RAD-KEY, REC-FS, LS-FS
"KAFKA" THERMAL PRINTER	RS 232/RS 485 CONVERTER
NEEDLE PRINTER "EPSON"	EXTERNAL POWER OUTPUT
TABLE FOR SCALE	